

# REELMAX FIRE HOSE REEL USERS GUIDE

## SWINGING ARM TYPE RMSM19-B / RMSM25-B SERIES

The reel must not be modified or dismantled before or during installation as such action would invalidate the product certification. When not in use, the hose reel should be restored to its as installed condition with the ball valve in the off position.

Do not use on live electrical equipment or liquids.  
Do not direct the jet at any personnel.  
Protect the hose reel system from frost.

General Assembly Drawing

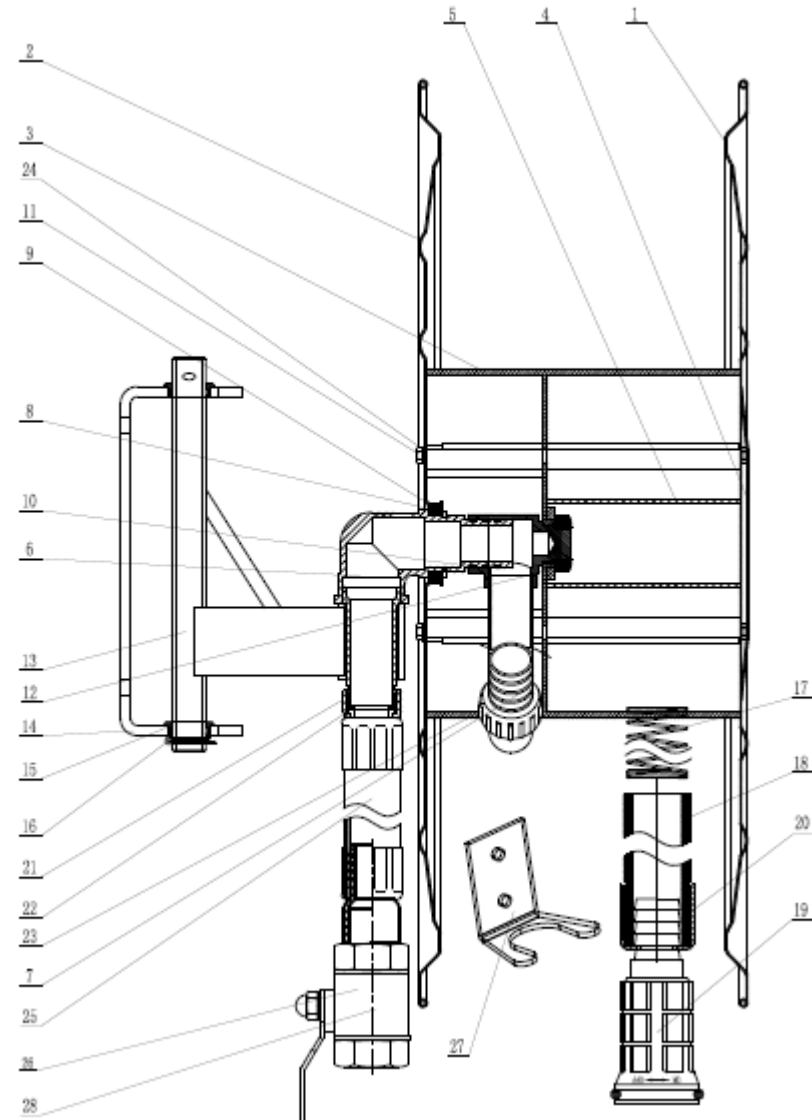

26				13	brass bush	2	
25				12	U-fixing board	1	
24	locking screw	1		11	swinging arm	1	
23	bush clamp	1		10	long screw	5	
22	valve	1		9	O-ring	2	
21	spring	1		8	center circlip	1	
20	al. sleeve	1		7	plastic ring	1	
19	nozzle	1		6	auto waterway	1	
18	hose	1		5	supporting tube	1	
17	nut	2		4	nameplate	1	
16	washer	2		3	plastic drum	1	
15	screw	2		2	left disk	1	
14	circlip	2		1	right disk	1	
No.	Name	Qty	Remarks	No.	Name	Qty	Remarks

RMSM19-B / RMSM25-B series manual swinging hose reels are designed for firefighting purposes only and up to EN671 and EN694 Standard.

#### Product Data

Model	Type	Hose specification (mm)	Reel Height A (mm)	Reel Width B (mm)	Reel Depth C (mm)	Min. Cabinet size (W*H*D) in mm
RMSM25-B	Manual	25*25/30m	600	570-580	210	760*720*230
RMSM19-B	Manual	19*20/30m	600-610	555	210	700*700*230

#### Please Note

In accordance with EN 671, hose for firefighting must be limited to 30m for 19mm (3/4") hose, and 25mm (1") hose

#### Installation

The hose should be fully run out, put under pressure and the following points checked.

1. A suitable and accessible location should be selected. The surface must be suitable to withstand a horizontal pull on the reel
2. Mark out four mounting holes as per dimension and position of the bracket in the drawing.
3. Drill the holes as marked to suit the prepared fasteners. Make sure that the point at which the Hose Reel is to be mounted is the horizontal centre-line on which the reel rotates.
4. Tighten the bracket onto the wall according to the holes, with prepared four fasteners, securely ensuring the hinge assembly is level.
5. Connect outlet end of the landing valve onto the fire reel winging pipe inlet.
6. Connect the water supply pipe onto inlet end of the valve
7. Carry out the fire reel commissioning as maintenance laid down in EN 671-3
8. Check ease of hose withdrawal in any direction and check for leaks and rewind hose in accordance with Name Plate instructions.
9. If being installed in a cabinet, it is mounted on a swinging arm which swings 180°.

#### Operating

1. Open the valve, pull hose towards fire, open nozzle to spray/jet and aim at base of fire.
2. After use, close the valve, drain water from hose, rewind the hose and close nozzle.

#### Operating Parameters

Water supply of 2 BAR g to 12 BAR g pressure, it's recommended that the supply be regulated to 4 BAR

## Maintenance

6 monthly inspection check for leaks as table:

Leak Location	Remedy	Leak Location	Remedy
Ball valve and inlet elbow	Tighten joints	Hose-waterway joint	Renew Clips
Ball valve	Renew valve	Hose	Renew hose
Nozzle	Replace nozzle	Waterway-inlet pipe	Renew O-ring seal

All 6 monthly and annual inspections and service should be carried out by qualified personnel who are familiar with EN671-3 requirements for maintenance records and tagging.

## Annual Inspection Procedure

The hose should be fully run out, put under pressure and the following points checked.

- A. Hose reel is unobstructed and free from damage and components not corroded or leaking operating instructions are clear and legible
- B. The location is clearly marked
- C. Brackets for wall mounting are suitable for their purpose and fixed and firm
- D. The flow of water is steady and sufficient
- E. The entire length of hose should be inspected for signs of cracking, distortion, wear or damage. If the hose shows any signs of defect, it shall be replaced, or proof tested to maximum permissible working pressure.
- F. Hose clips or bindings are of the correct type and are securely fastened.
- G. Hose drum rotates freely in both directions
- H. For swinging reels, check that pivot rotates easily and that the reel swings through 180°
- I. On manual reels, check the valve is of correct type and that it operates easily and correctly.
- J. Check the condition of the water supply pipe work; particular attention should be paid to any flexible pipe work for signs of damage or wear.

- K. If fitted with a cabinet, check for signs of damage and check that the cabinet doors open freely
- L. Check that the nozzle is of the correct type and easy to operate
- M. Check the operation of any hose guide and ensure they are correctly and firmly fixed
- N. Leave the hose reel and hose system ready for immediate use. If any extensive maintenance is necessary, the hose reel or hose system should be labeled OUT OF ORDER and the competent Person should inform the user/owner.
- O. When transparent material is used as a part of the construction of the door, then this shall not be used as the emergency access to the hose reel.
- P. An opening /closing device of the cabinet shall be provided to allow periodical inspection and maintenance. The opening device shall have provision for a security seal to be fitted. The force necessary to open and secure the seal shall be not less than 20N and not more than 40N.
- Q. The screw down valve shall be positioned in the cabinet for manual hose reel in such a way that there is at least 35mm free space around the external diameter of the hand wheel, when the valve is in any position from fully open to fully closed.

## Discharge Property

Nozzle Setting	Nozzle Diameter	Inlet Size	Flow Rate at 2 bar/ 6 bar (Jet/Spray) (L/M)	Throw Range at 2 bar
Jet/Spray	6 mm	3/4"(19mm)	> 24/41	> 11.2
Jet/Spray	7mm	1"(25mm)	> 31/53	> 11.2

REVISION	V4	DATE	23/08/2021
----------	----	------	------------